

Micro Weld Fittings

M Series

Features

- ⦿ Compact design
- ⦿ Sizes range from 1/8" to 1/2" and 6 mm to 12 mm
- ⦿ Applicable to miniaturized tubing system



Process Specification

| Item | Process Specification | Standard Cleaning and Packaging Process (FC-01) | Special Cleaning and Packaging Process (FC-02) |
|--------------------------|-----------------------|---|--|
| | Material | | 316 SS, 316L SS |
| Wetted Surface Roughness | | Ra 10 μin. (0.25 μm) | Ra 5 μin. |
| Polishing Process | | Machine finished | Electropo |

Reducing Unions

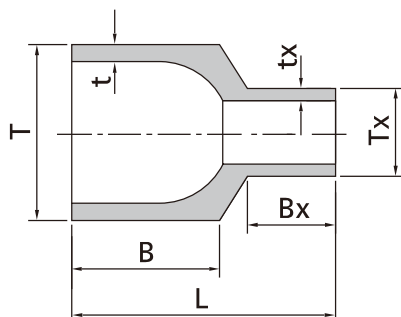

| Fractional | | | | | Dimensions, in. | |
|-------------------|------------------------|--------------------|-------------------------|-----------------------|-----------------|-------------|
| T-Tube O.D. (in.) | t-Wall Thickness (in.) | Tx-Tube O.D. (in.) | tx-Wall Thickness (in.) | Basic Ordering Number | L | B |
| 1/4 | 0.035 | 1/8 | 0.028 | -WU1-TB4-TB2 | 0.75 (19.1) | 0.42 (10.7) |
| 3/8 | 0.035 | 1/4 | 0.025 | -WU1-TB6-TB4 | 0.75 (19.1) | 0.42 (10.7) |

F-07 Weld Fittings

Fittings

| Metric | | | |
|------------------|-----------------------|-----------------------|-----|
| T-Tube O.D. (mm) | t-Wall Thickness (mm) | Basic Ordering Number | |
| 6 | 1.0 | -WL1-MTB6 | 10. |
| 8 | 1.0 | -WL1-MTB8 | 11. |
| 10 | 1.0 | -WL1-MTB10 | 11. |
| 12 | 1.0 | -WL1-MTB12 | 13. |

Valves

Extended Leg 90° Union Elbows

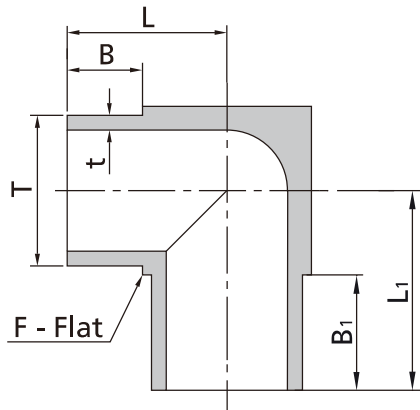

Regulators

| Fractional | | | | | | |
|-------------------|------------------------|-----------------------|----------------------|-------------|------------|-------------|
| T-Tube O.D. (in.) | t-Wall Thickness (in.) | Basic Ordering Number | Dimensions, in. (mm) | | | |
| | | | B | B1 | F | L |
| 1/4 | 0.035 | -WL1-TB4-1 | 0.25 (6.4) | 0.45 (11.4) | 5/16 (7.9) | 0.41 (10.4) |
| 1/4 | 0.035 | -WL1-TB4-2 | 0.25 (6.4) | 0.50 (12.7) | 5/16 (7.9) | 0.41 (10.4) |
| 1/4 | 0.035 | -WL1-TB4-3 | 0.45 (11.4) | 0.45 (11.4) | 5/16 (7.9) | 0.61 (15.5) |
| 1/4 | 0.035 | -WL1-TB4-4 | 0.50 (12.7) | 0.50 (12.7) | 5/16 (7.9) | 0.66 (16.8) |

Filters

Reducing 90° Union Elbows

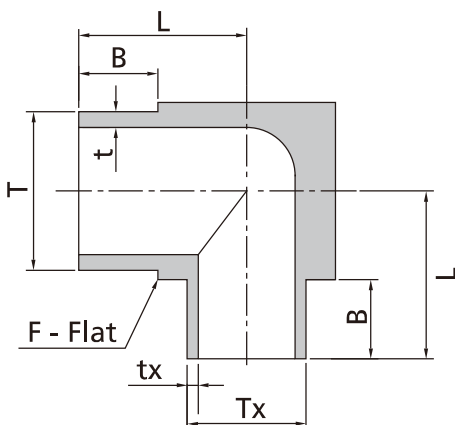

Tubing

Integr
Syste

45° Union Elbows

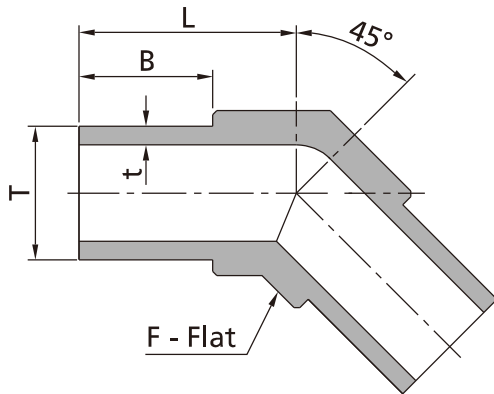

| Fractional | | | |
|-------------------|------------------------|-----------------------|-------------|
| T-Tube O.D. (in.) | t-Wall Thickness (in.) | Basic Ordering Number | Dim |
| | | | L |
| 1/4 | 0.035 | -WV1-TB4 | 0.41 (10.4) |
| 3/8 | 0.035 | -WV1-TB6 | 0.47 (11.9) |
| 1/2 | 0.049 | -WV1-TB8 | 0.53 (13.5) |

Tribows

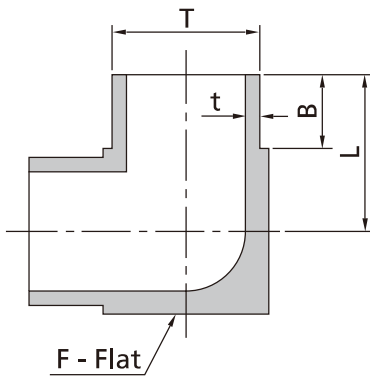

| Fractional | | | |
|-------------------|------------------------|-----------------------|-------------|
| T-Tube O.D. (in.) | t-Wall Thickness (in.) | Basic Ordering Number | Dim |
| | | | L |
| 1/4 | 0.035 | -WB1-TB4 | 0.41 (10.3) |
| 3/8 | 0.035 | -WB1-TB6 | 0.47 (11.9) |
| 1/2 | 0.049 | -WB1-TB8 | 0.53 (13.5) |



| Metric | | | |
|------------------|-----------------------|-----------------------|-------------|
| T-Tube O.D. (mm) | t-Wall Thickness (mm) | Basic Ordering Number | Dim |
| | | | L |
| 6 | 1.0 | -WB1-MTB6 | 10.4 (0.41) |

Union Tees

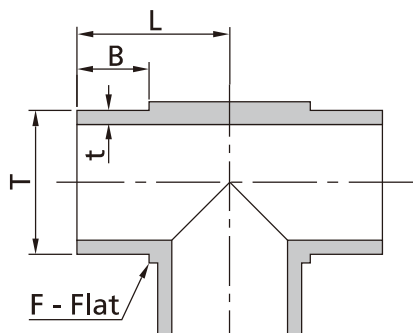

| Fractional | | | |
|-------------------|------------------------|-----------------------|-------------|
| T-Tube O.D. (in.) | t-Wall Thickness (in.) | Basic Ordering Number | Dim |
| | | | L |
| 1/8 | 0.028 | -WT1-TB2 | 0.41 (10.4) |
| 1/4 | 0.035 | -WT1-TB4 | 0.41 (10.3) |
| 3/8 | 0.035 | -WT1-TB6 | 0.47 (11.9) |
| 1/2 | 0.049 | -WT1-TB8 | 0.53 (13.5) |

Extended Branch Leg Union Tees

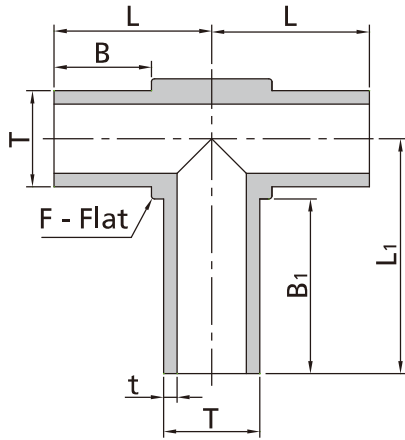

| Fractional | | | | | | |
|-------------------|------------------------|-----------------------|----------------------|----------------|------------|----------------|
| T-Tube O.D. (in.) | t-Wall Thickness (in.) | Basic Ordering Number | Dimensions, in. (mm) | | | |
| | | | L | L ₁ | B | B ₁ |
| 1/4 | 0.035 | -WT1-TB4-45 | 0.41 (10.4) | 0.61 (15.5) | 0.25 (6.4) | 0.41 (10.4) |

Extended Run Leg Union Tees

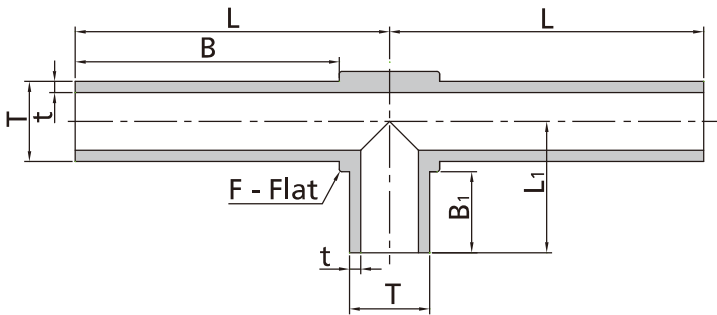

There may be a minor step between run ends at drill intersection.

| Fractional | | | | | | |
|-------------------|------------------------|-----------------------|----------------------|----------------|-------------|----------------|
| T-Tube O.D. (in.) | t-Wall Thickness (in.) | Basic Ordering Number | Dimensions, in. (mm) | | | |
| | | | L | L ₁ | B | B ₁ |
| 1/4 | 0.035 | -WT1-TB4-98 | 0.98 (24.9) | 0.41 (10.4) | 0.83 (21.1) | 0.25 (6.4) |

Reducing Tees

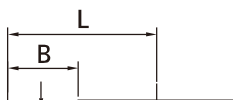

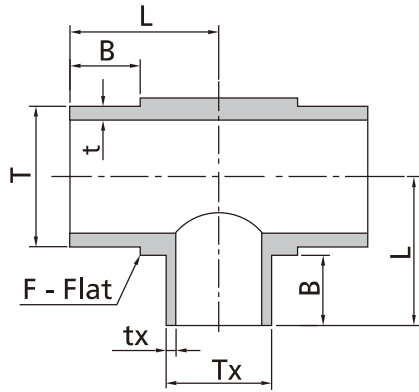

| Metric | | | | | |
|------------------|-----------------------|-------------------|------------------------|-----------------------|------------|
| T-Tube O.D. (mm) | t-Wall Thickness (mm) | Tx-Tube O.D. (mm) | tx-Wall Thickness (mm) | Basic Ordering Number | Dim L |
| 10 | 1.0 | 6 | 1.0 | -WT1-MTB10-MTB10-MTB6 | 11.9 (0.4) |
| 12 | 1.0 | 6 | 1.0 | -WT1-MTB12-MTB12-MTB6 | 0.53 (13) |
| 12 | 1.0 | 8 | 1.0 | -WT1-MTB12-MTB12-MTB8 | 0.53 (13) |

Union Crosses

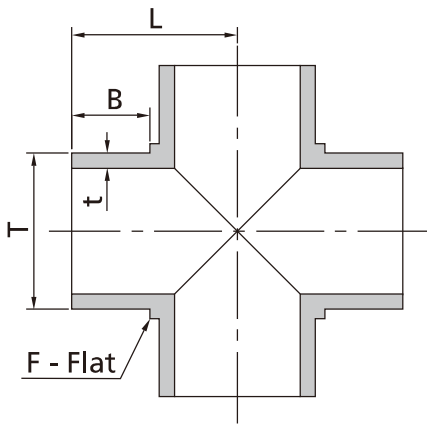

| Fractional | | | |
|-------------------|------------------------|-----------------------|-------------|
| T-Tube O.D. (in.) | t-Wall Thickness (in.) | Basic Ordering Number | Dim L |
| 1/8 | 0.028 | -WC1-TB2 | 0.41 (10.4) |
| 1/4 | 0.035 | -WC1-TB4 | 0.41 (10.3) |
| 3/8 | 0.035 | -WC1-TB6 | 0.47 (11.9) |
| 1/2 | 0.049 | -WC1-TB8 | 0.53 (13.5) |

| Metric | | | |
|------------------|-----------------------|-----------------------|-------------|
| T-Tube O.D. (mm) | t-Wall Thickness (mm) | Basic Ordering Number | Dim L |
| 6 | 1.0 | -WC1-MTB6 | 10.4 (0.41) |
| 8 | 1.0 | -WC1-MTB8 | 11.9 (0.47) |
| 10 | 1.0 | -WC1-MTB10 | 11.9 (0.47) |
| 12 | 1.0 | -WC1-MTB12 | 13.5 (0.53) |